

Esco Ascent™ Opti Titramax
Model SPT

Ascent™ Opti Titramax

Introduction

Titration analysis is a common laboratory method done to quantitatively identify the unknown concentration of a specific analyte. During this analysis, operators are often exposed to chemical fumes, vapors, and odor.

As an advocate of safety, Esco introduces the Ascent™ Opti Titramax, a specialized ductless fume hood designed to enclose titration devices such as burettes and auto-titrators while containing toxic vapour. Its ductless design offers customers full mobility and convenience as no complex installation system is required.

Designed for Enhanced Usability and Efficiency

The Titramax is specifically designed to provide the operator with a high level of usability, comfort and visibility.

- Angled front sash ergonomically allows users to work further into the hood without strain, eliminating operator fatigue and increasing productivity.
- Transparent frameless acrylic front window and sides provide a high degree of visibility and operator comfort.
- Ergonomic oval-shaped apertures for hands in the front window allows for maximum reach within the work zone while providing the operator with extra protection from any possible chemical spillage.
- The sliding sash design provides easy access during loading and setting up of titration equipment inside the enclosure.
- Elongated height to accommodate a typical 50 ml burette, a 500 ml flask and a magnetic stirrer.
- Curved front edge minimizes airflow turbulence and improves user comfort.
- Electronic ballast for the fluorescent lighting provides zero-flicker with increased energy efficiency, reliability and service life with a lower heat output.
- Electrical pass-through on the back wall of the unit provide convenient access to power sources for devices such as magnetic stirrer/ hot plate.

Enhanced Filtration System

Esco's Nanocarb™ activated carbon filters are constructed in order to ensure maximum filter efficiency, retention capacity and operator protection. Esco's research scientists and engineers, working in consultation with world-leading authorities on adsorption science, have developed the following set of unique technologies:

- Optimized retention capacity.
- Generously sized filters with more activated carbon by weight retain more chemicals and last longer.
- Quick-change out filter clamping mechanism allows filter replacements to be carried out with minimal tools;
- Diffusion technology to ensure even filter loading and better airflow uniformity.
- Optional sensing technology (VOC sensor) is available as an aid to predict filter saturation and warn the user to change the filters.

Highest Quality Construction

- Industrial-grade main body constructed of electrogalvanized steel: with an abrasion resistant white after oven-baked powder-coated finish.
- Esco Isocide™ antimicrobial surface on all painted surfaces minimizes surface contamination.
- Permanently lubricated direct drive centrifugal fan(s); energy efficient external rotor motor type design reduces operating costs; extremely low noise and vibration levels due to proprietary construction and mounting technology.
- Industry exclusive baffle design for improved containment and efficient removal of chemical fumes from the work zone.

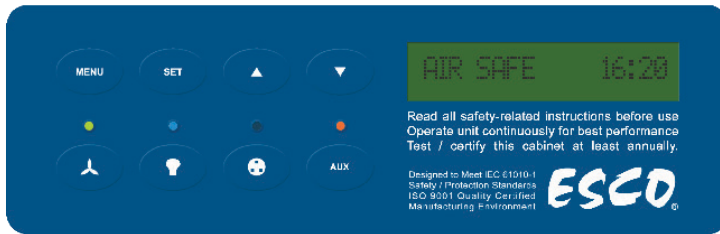

Sentinel™ Silver Microprocessor Control, Alarm, Monitoring System

Esco's Sentinel™ microprocessor-based hood control systems supervises operation of all hood functions. The user-friendly microprocessor control system is fully configurable according to operator's requirements and comes equipped with a number of enhanced features to promote cabinet usability.

- Continuous monitoring of hood airflow is displayed on a bright, easy-to read LCD panel.

- Audible and visual alarms for low airflow and/or unsafe sash positions.
- An integrated, temperature-compensated, true airflow velocity sensor provides an accurate airflow reading despite room temperature fluctuation.
- An administrator controlled PIN (Personal Identification Number) can be set to restrict access to main menu.

Options and Accessories

The Titramax is available with an optional Volatile Organic Compounds (VOC) sensor and a mobile base cabinet.

Guide to Models					
SPT -					
External Width	Code	Back Wall Construction	Code	Electrical Rating	Code
0.9 m (3 ft.)	3	EG Steel	A	220-240 VAC, 50 Hz	1
1.2 m (4 ft.)	4	Acrylic (transparent back wall)	B	115 VAC, 60 Hz	2
				220-240 VAC, 60 Hz	3

2

General Specifications, Ascent™ Opti Titramax					
Model	220-240 VAC, 50 Hz	SPT-3A1 2040301	SPT-3B1 2040304	SPT-4A1 2040307	SPT-4B1 2040310
	115 VAC, 60 Hz	SPT-3A2 2040302	SPT-3B2 2040305	SPT-4A2 2040308	SPT-4B2 2040311
	220-240 VAC, 60 Hz	SPT-3A3 2040303	SPT-3B3 2040306	SPT-4A3 2040309	SPT-4B3 2040312
Nominal Size		0.9 meters (3 ft)		1.2 meters (4 ft)	
External Dimensions (W x D x H)		840 x 700 x 1550 mm (33" x 27.6" x 61.0")		1145 x 700 x 1550 mm (45" x 27.6" x 61.0")	
Internal Dimensions (W x D x H)		790 x 600 x 1210 mm (31.1" x 23.6" x 47.6")		1095 x 600 x 1210 mm (66.7" x 23.6" x 47.6")	
Material Construction	Main Body	1.2 mm 18 gauge electro-galvanized steel with white oven-baked epoxy-polyester ISOCIDE™ antimicrobial powder coated finish			
	Side Walls	6 mm Acrylic Glass			
	Rear Wall	Powder coated E.G. Steel	Acrylic Glass	Powder coated E.G. Steel	Acrylic Glass
	Work Top	44 mm Thick Epoxy			
	Sash Material	Acrylic glass			
	Configuration	2-door sliding panels with ergonomic arm ports			
Filtration System		Nanocarb™ Filters (Type A-H)			
Fluorescent Light Intensity		>350 lux (> 28 foot candles) at work surface level			
Controller		Esco Sentinel™ Silver Microprocessor Controller			
Electrical Pass-Through		2			
Net Weight		145 kg (319.7 lbs)		165 kg (363.8 lbs)	
Shipping Weight		160 kg (352.7 lbs)		180 kg (396.8 lbs)	
Shipping Dimensions, Maximum (W x D x H)		1120 x 850 x 1820 mm (44.1" x 33.5" x 71.7")		1450 x 850 x 1820 mm (57.1" x 33.5" x 71.7")	

Model SPT, Ascent™ Opti Titramax Ductless Fume Hood Engineering Drawing, 0.9 m to 1.2 m (3 ft to 4 ft width)

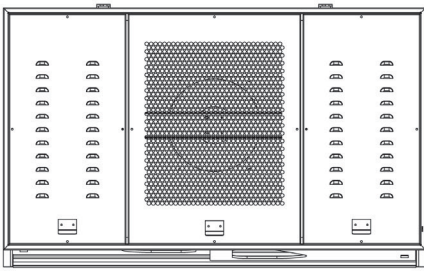

Top View, Electrical Panel

- 1. Sample Port
- 2. Filter ID Window
- 3. Sliding Sash
- 4. Pass-through ports for electrical or service connections
- 5. Sentinel™ Silver Microprocessor Control System
- 6. Ergonomic Arm Ports
- 7. Sash Handle
- 8. Fan
- 9. Nanocarb™ Filter
- 10. Baffle
- 11. Epoxy Worktop

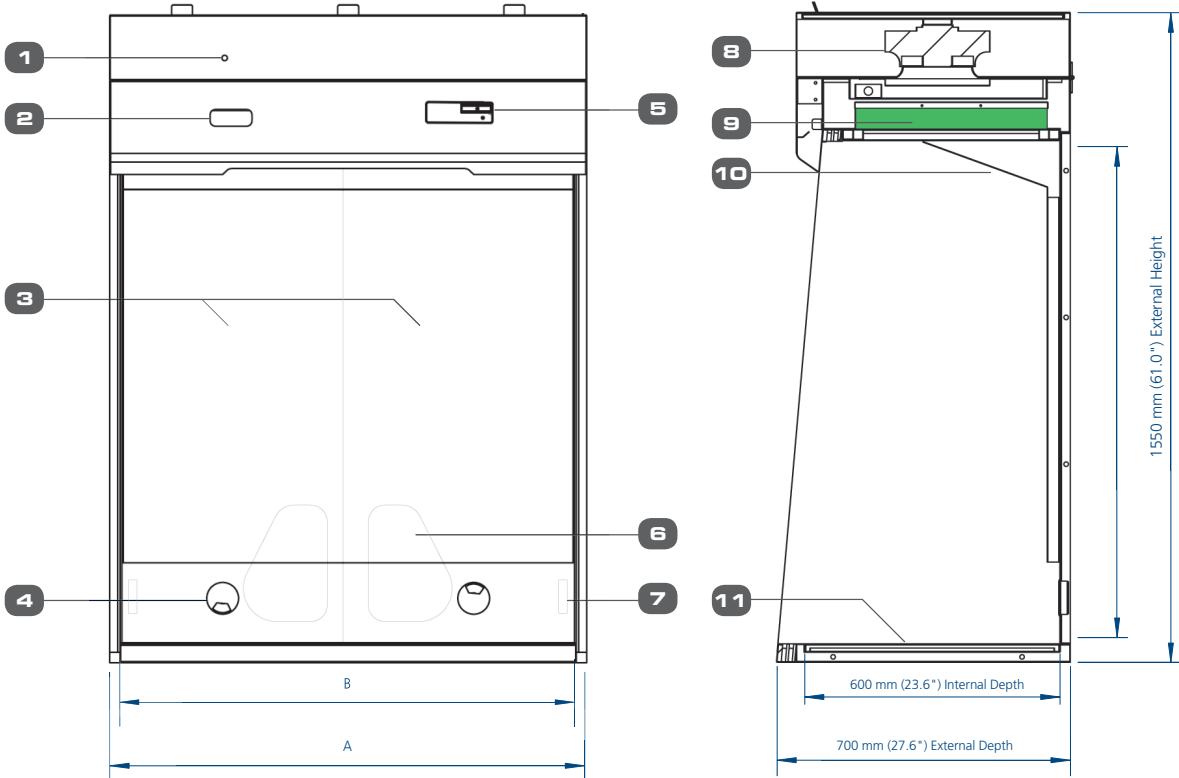

Model	A (External Width)	B (Internal Width)
SPT-3	840 mm (33")	790 mm (31.1")
SPT-4	1145 mm (45")	1095 mm (43.1")

Model MBT, Mobile Base cabinet for SPT 0.9 m to 1.2 m (3 ft to 4 ft width)

- 1. Hole for cabinet mouting
- 2. Shelf Tray
- 3. 5mm side perspex acrylic
- 4. Castor wheels

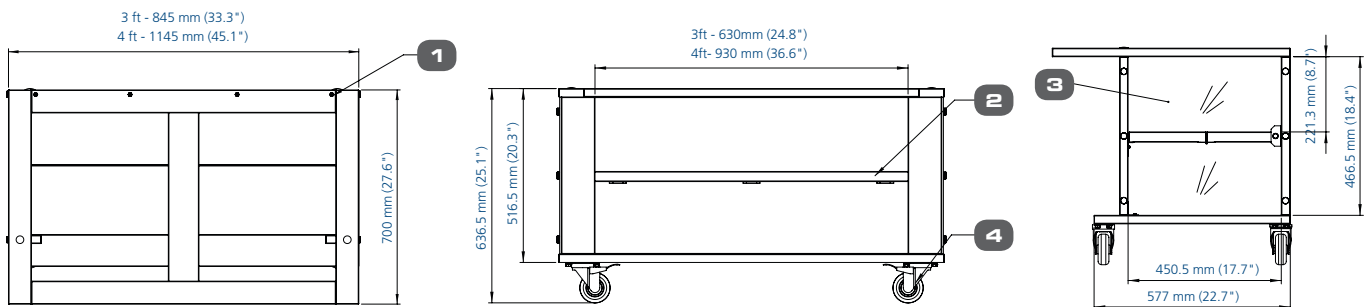

ESCO LIFESCIENCES GROUP

42 LOCATIONS IN 21 COUNTRIES ALL OVER THE WORLD



- Global Offices
- Joint Ventures
- Licensee
- Distributors
- Factories
- R&D Centers
- Regional Distribution Centers

Join us on Social Media and Download our Apps!



Filtra Check App
The World's First Chemical
Evaluation App



Esco Social Media
and Apps



Esco Micro Pte. Ltd. • 21 Changi South Street 1 • Singapore 486 777
Tel +65 6542 0833 • Fax +65 6542 6920 • mail@escolifesciences.com
www.escolifesciences.com

Esco Technologies, Inc. • 903 Sheehy Drive, Suite F, Horsham, PA 19044, USA
Tel: +1 215-441-9661 • Fax 484-698-7757
eti.admin@escolifesciences.com

Esco Lifesciences Group Offices: Bangladesh | China | Denmark | Germany | Hong Kong | India | Indonesia | Italy | Japan | Lithuania | Malaysia | Myanmar | Philippines | Russia | Singapore | South Africa | South Korea | Taiwan | Thailand | UAE | UK | USA | Vietnam